

OPTIMAL COMPONENT SUPPORT

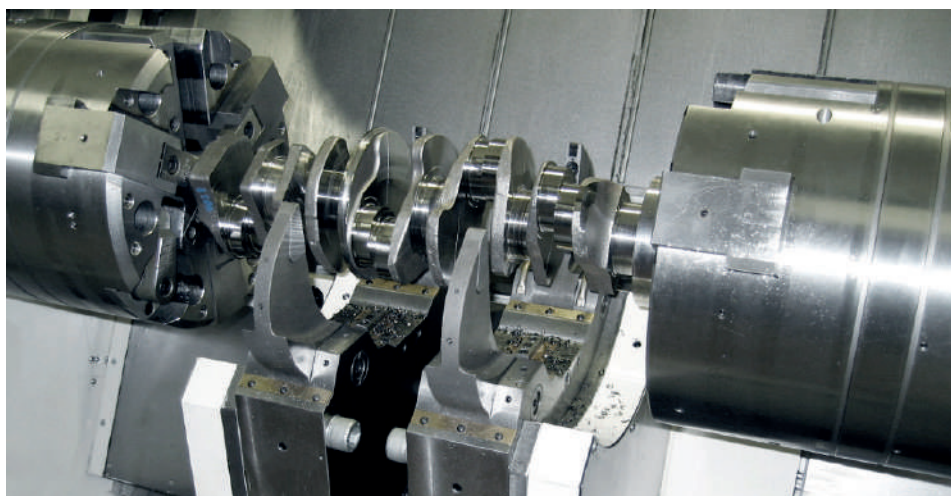

Optimal support of components for every application, e.g. crankshaft machining



SELF-CENTERING STEADY RESTS

With self-centering steady rests, RÖHM makes an important contribution toward the support of slender turned parts on lathes and meets all requirements for a large clamping range without change elements, a short and sturdy design, high centering precision and repeatability, as well as precision stability for clamping pressure changes and central lubrication.

ADVANTAGES AT A GLANCE

- ⊕ Support of components with extreme center precision and repeatability thanks to optimized cam lever system
- ⊕ Standardized equipped with central lubrication for use under difficult conditions and with high dirt accumulation
- ⊕ Large clamping range without change elements thanks to special curved geometry

Simple attachment of a safety valve and dosing valves for the central lubrication system to increase maintenance friendliness for SLZN or SLZN-B

Safety valve for guaranteeing operational safety in the event of a pressure drop (optionally for SLZ-047)

Hydraulic or pneumatic actuation possible

Central lubrication or manual lubrication possible, depending on the application

All versions available with and without chip protection

Depending on the application, round or cylindrical rollers available (except for SLZK)

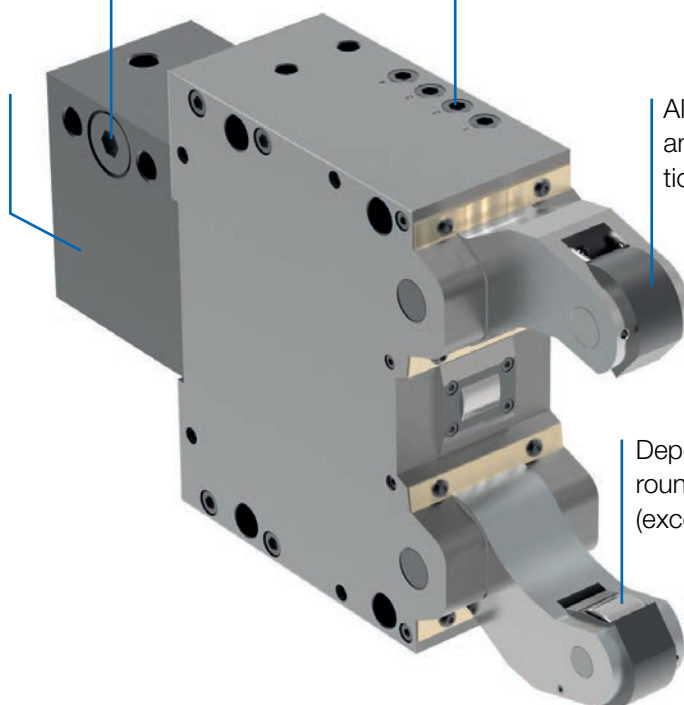

Self-centering steady rests



Function description

Different attachment options allow possible use for turning, facing, centering, drilling, internal machining, copy turning, etc., both as a stationary as well as a rotating steady rest in any angular position relative to the lathe tool.

Also in the case of a stationary steady rest, the shaft can be machined along the entire length since, on the one hand, the opening between the rollers leaves room for tools and on the other hand, the rollers reclaim self-centering. Here, 2 supporting steady rests are to be provided so that one of these can support the workpiece over the entire width of the roller.

The cylinder installed to actuate the steady rest can be selected for hydraulic or pneumatic actuation. The only difference is the size of the piston surfaces.

List of abbreviations

SP	=	Air purge connection
ZS	=	Central lubrication of the steady rest
HN	=	Check via steady rest proximity switch (not included in delivery) in the open position
HK	=	Stroke control rod
RZ	=	Rollers, cylindrical
RB	=	Rollers, convex

Standard configuration

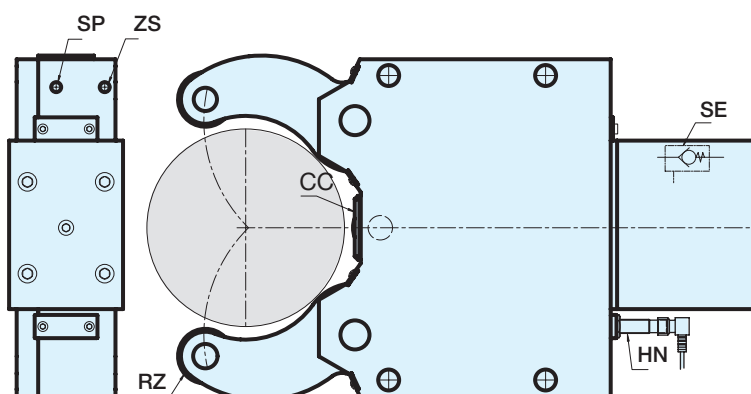

The standard steady rest is configured as follows:

- Cylindrical rollers
- Pressurization
- Central lubrication
- Axially extended cylinder with safety valve (except SLZ-047)
- Proximity switch component (open steady rest) for possible using of HN
- Device for manual lubrication via grease cup or oiler



Function description

Lubrication

Only one connection is required for the central lubrication system. The dosing units for the rollers are integrated in the steady rest body and ensure sufficient lubrication in the corresponding time interval.

Oil central lubrication (standard)

RÖHM steady rests are standard-equipped with a central lubrication system. The dosing valves required for lubrication are built into the steady rest body. Lubrication intervals (depending on load) 2-5 minutes at an operating pressure of 16-50 bar.

Manual lubrication (option)

Steady rest for moderate load and low dirt accumulation. Lubrication points and rollers are supplied with grease via grease nipples and grease gun. Lubrication intervals every 4 to 8 operating hours, depending on application.

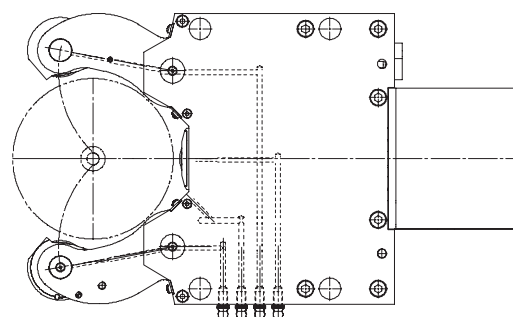
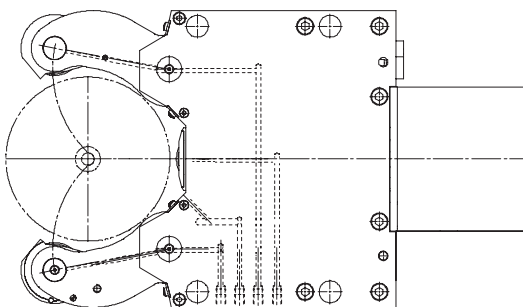

Rollers

The rollers are supported by roller bearings radially and axially. In the standard version, these are cylindrical or convex. In the case of conical workpieces and for follower rests arrangement, convex rollers are to be used. Here, too, customized designs on request supplement the product range.

Cylindrical rollers
roller version for
standard inserts

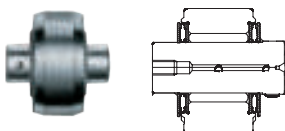

Convex rollers
for conical workpieces and
for following steady rest arrangement

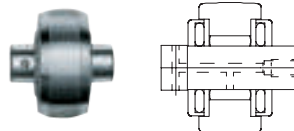

Customized rollers
on request

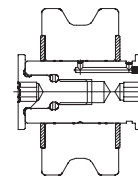



Standard accessories of SLZN series

Clamping arm control system SLZ-HN

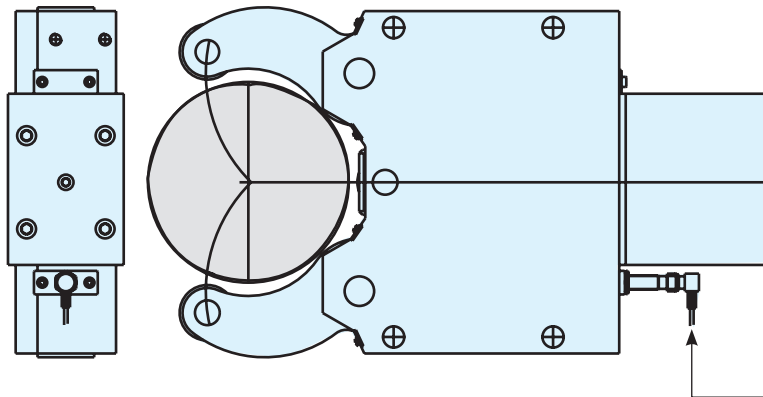

There is the option of attaching a sensor (proximity switch) to the steady rests as standard, which measures the position of the opened steady rest. This option is not available for the steady rest of type SLZ-047. The proximity switch is not included in the delivery of the steady rest.

Not included in the scope of delivery

Control system of the clamping arms SLZ-HK

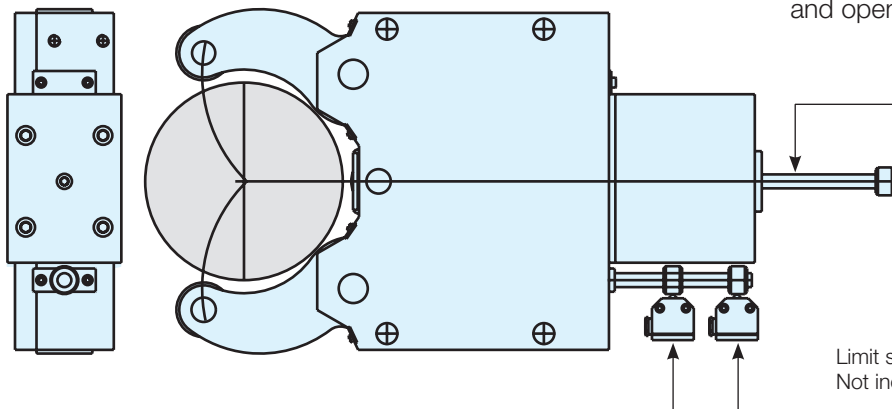

All steady rests of type SLZN and SLZNB can be equipped with holders and rods or only with rods, in order to be able to control the clamping position and open position using limit switches.

Position only for SLZ-047

Limit switches/path measuring system
Not included in the scope of delivery



Technical data

Standard accessories of SLZN series

Safety valve SE

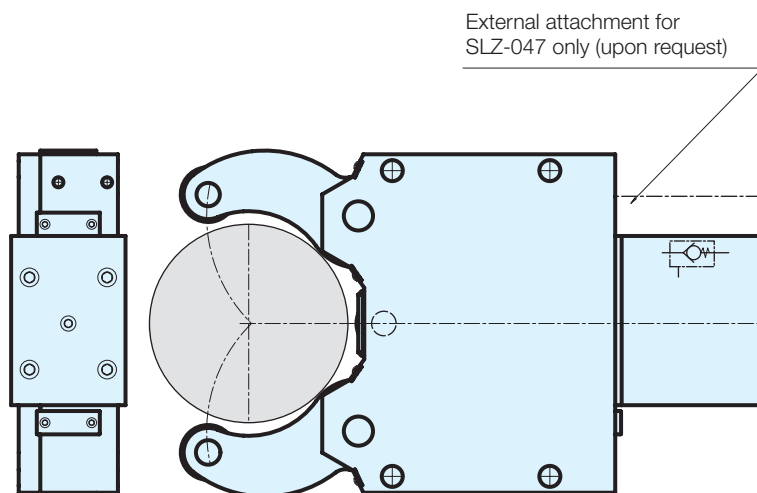

All standard steady rests are equipped with a safety valve integrated in the cylinder. If the clamping pressure in the cylinder should be interrupted, the valve prevents the steady rest from opening. With moving applications, the safety valve isn't necessary. We would be happy to help you if need be. This device is available as an option for the SLZ-047 series.

Pressurization

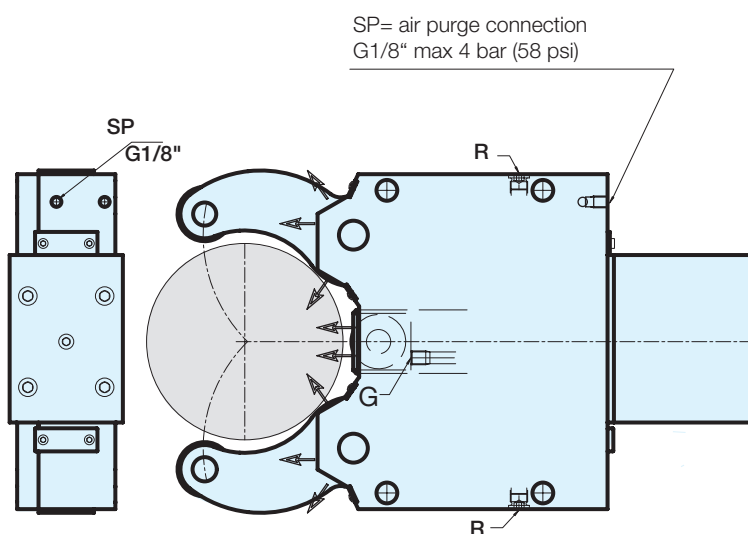

All RÖHM steady rests have a G 1/8" air purge connection; This system protects the body of the steady rest from chip and dust penetration. When the steady rest is completely open, the air consumption is automatically reduced, but not completely interrupted to prevent unnecessary air consumption. The system includes the cleaning of the middle roller bearings. To activate this option, the screw „G“, which is located in the housing floor, must be removed. The pressure can vary between a minimum of 2 bar and maximum of 4 bar (58 psi). The steady rest can also be used without the air purge. Drain holes are on the top and bottom part of the steady rest housing. It is recommended that the lower one of the two seals be loosened to allow the cooling water to drain and to prevent penetration of contaminants into the body of the steady rest.



Set-up princicple SLZN

All steady rests have an engraved identification number. This number must be provided when ordering replacement parts.

Components SLZN/SLZNB

- | | |
|-------------------------|----------------------|
| 1. Body | 10. Scraper band |
| 2. Cam segment | 11. Axle and rollers |
| 3. Clamping arm outside | 12. Cover |
| 4. Clamping arm center | 13. Cylinder housing |
| 5. Bolt and roller | 14. Cylinder flange |
| 6. Clamping arm arbore | 15. Piston |
| 7. Return lever | 16. Piston rod |
| 8. Roller center | 17. Pressure sleeve |
| 9. Roller | 18. Scraper center |

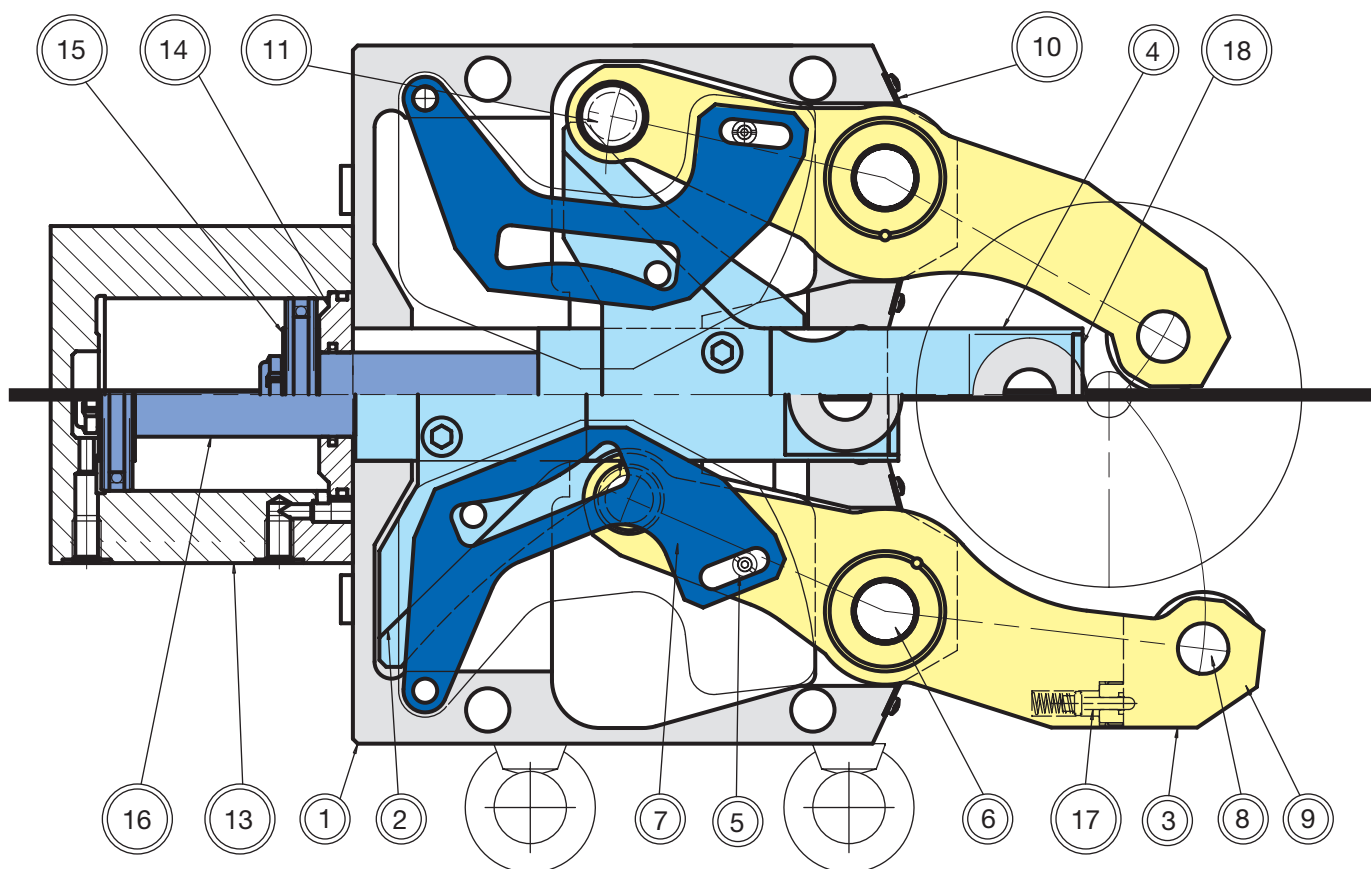
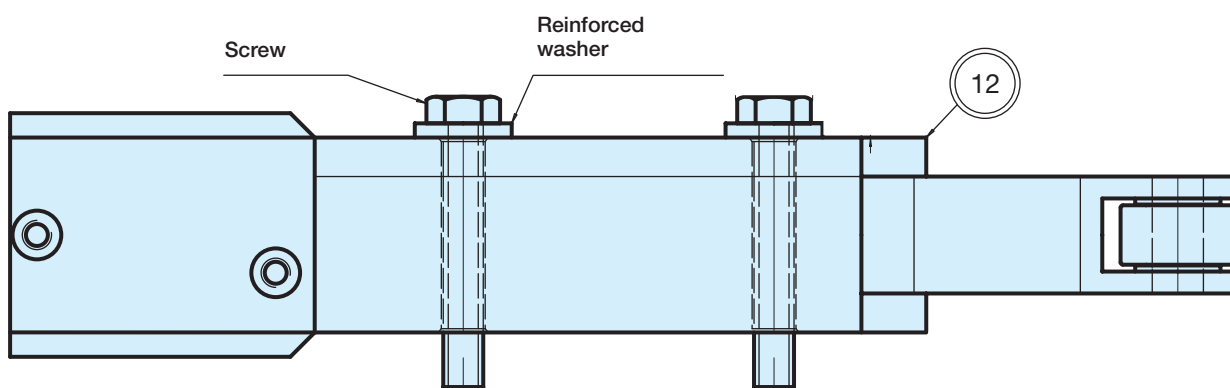



Notes

Notes



Self-centering steady rests

SLZN - standard design

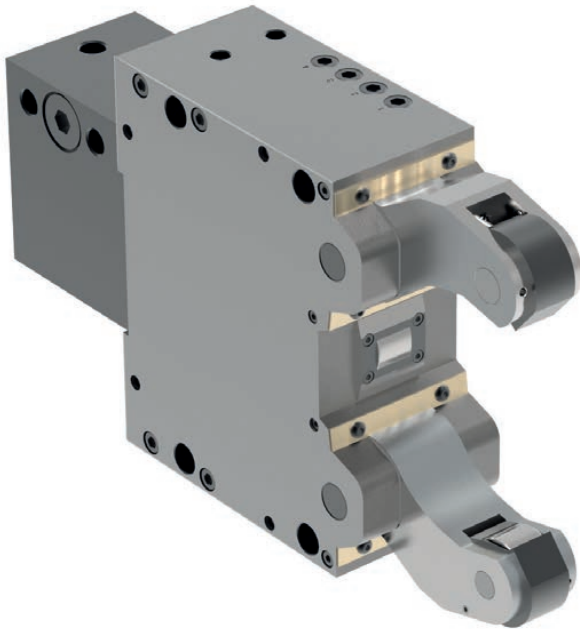

APPLICATION

Support of slender shafts for rational turning and end machining.

TYPE

Standard version with cylinder mounted at rear.

CUSTOMER BENEFITS

- ⊕ Large clamping range without change elements
- ⊕ Operational safety thanks to safety valve, even if pressure drops (SLZ-047 optional)
- ⊕ Compact and sturdy design for variable use
- ⊕ High centering precision and repeatability thanks to proven cam lever system
- ⊕ Resilient chip protection for optimal workpiece wiping (for version „with chip protection“)
- ⊕ Purge air connection to prevent penetration of dirt inside the steady rest

TECHNICAL FEATURES

- Central lubrication or manual lubrication possible, depending on the operating conditions
- Standard version available with cylindrical or convex rollers
- Available with and without chip protection
- Prepared for end position check, except SLZ-047 (limit switch not included in the scope of delivery)

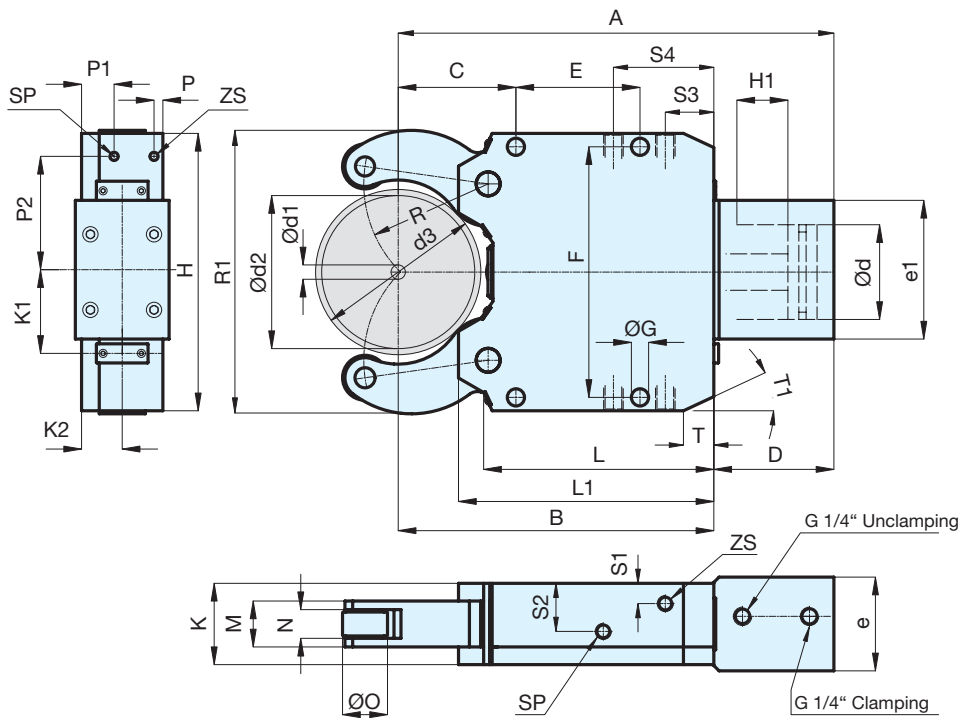

Self-centering steady rests SLZN



Self-centering steady rests

SLZN - standard design

C 15

Self-centering steady rests **SLZN** - oil or air operated **with mounted cylinder**

Spannbereiche Typ	SLZ 047	SLZN 067	SLZN 08105	SLZN 1152	SLZN 1517	SLZN 40200	SLZN 325	SLZN 50315	SLZN 85350
Clamping range - with chip protection mm	15-62	11-70	16-101	22-140	25-158	40-195	40-240	50-305	85-345
Clamping range - without chip protection mm	4-70	6-75	8-105	11-152	15-170	40-200	30-250	50-315	85-350
Max. radial clamping range - d_3 mm	70	79	105	161	170	200	250	320	350
With chip protectors RZ	685751	1685567	1685571	1685575 ▲	1685579 ▲	1685583 ▲	1685587 ▲	1685591 ▲	1685595 ▲
With chip protectors RB	-	1685568	1685572	1685576 ▲	1685580 ▲	1685584 ▲	1685588 ▲	1685592 ▲	1685596 ▲
Without chip protectors RZ	685753	1685569	1685573	1685577 ▲	1685581 ▲	1685585 ▲	1685589 ▲	1685593 ▲	1685597 ▲
Without chip protectors RB	-	1685570	1685574	1685578 ▲	1685582 ▲	1685586 ▲	1685590 ▲	1685594 ▲	1685598 ▲
d1 mm	4	6	8	11	15	40	30	50	85
d2 mm	70	75	105	152	170	200	250	315	350
d3 mm	70	79	105	161	170	200	250	315	350
A mm	206	214	279,5	432,5	440,5	459,5	617,5	699	716,5
B mm	137	149	197	306	314	333	448	510	530
C mm	51	52	70	115	123	138	146	203	198
D mm	69	65	82,5	126,5	126,5	126,5	162	186,5	186,5
E mm	64	66	85	135	135	135	240	270	270
F mm	118	140	170	262	262	262	365	400	400
G mm	11	11	14	18	18	18	23	23	23
H mm	132	160	190	290	290	290	400	440	440
K mm	54	63	75	85	85	85	110	145	145
L mm	102	108,5	146	223	223	223	328,5	353,5	353,5
L1 mm	115,5	125,5	164	251	251	251	361	394,5	394,5
Clamping arm width M mm	20	28	35	48	48	48	60	75	75
Roller width N mm	11,5/9	17,5/14	20,5/18	30/25	30/25	30/25	40/35	45/40	45/40
O mm	19	24	35	47	47	47	52	60	60
P mm	-	9,75	-	9,5	9,5	9,5	12,5	21,5	21,5
P1 mm	-	8,75	-	34	34	34	12,5	68,5	68,5
P2 mm	-	51,5	-	117,5	117,5	117,5	160	183	183
R mm	48,5	55	74,5	122	130	143,5	178,5	209	229
S1 mm	8	-	10	-	-	-	-	-	-
S2 mm	23	-	40	-	-	-	-	-	-
S3 mm	10	-	28	-	-	-	-	-	-
S4 mm	34,5	-	28	-	-	-	-	-	-
K ₁ mm	-	51,5	59,5	85	85	85	110	140	140
K2 mm	-	31	36,5	42,5	42,5	42,5	55	59,5	59,5
d mm	40	35	50	80	80	80	100	100	100
e mm	60	62	68	98	98	98	124	142	143
e1 mm	87	22	92	145	145	145	136	156	175
T mm	-	-	-	-	-	-	45	31,5	54,5/22
T1	-	-	-	-	-	-	30°	30°	18°/40°
R1 mm	121	144	190	291	303	326	394	483	512
Weight kg	7	10	14,5	47	47	48	115	185	188
ZS	M 10x1	G 1/8"	G 1/8"	G 1/8"	G 1/8"	G 1/8"	G 1/8"	G 1/8"	G 1/8"
SP	G 1/8"	G 1/8"	G 1/8"	G 1/8"	G 1/8"	G 1/8"	G 1/8"	G 1/8"	G 1/8"
Cylinder-Ø	C40	C35	C50	C80	C80	C80	C100	C100	C100
Cylinder surface area cm ²	12,5	9,6	19,6	50	50	50	78,5	78,5	78,5
Max. operating pressure bar	25	54	53	62	68	40	57	80	61
Operating pressure bar	6-20	6-30	8-30	8-40	8-44	8-25	8-42	8-58	8-40
Clamping force per roller at max. operating pressure N	830	960	1960	6500	6500	4160	11000	15000	10460
Max. permissible clamping force per roller N	1040	1700	3500	10000	10000	6670	15000	20000	16000
Clamping force per roller at 20 bar N	830	640	1300	3300	3300	3300	5200	5200	5200
Centering accuracy over the entire clamping range mm	0,02*	0,02*	0,02*	0,04*	0,04*	0,04*	0,05*	0,06*	0,06*
Repeat accuracy for the same clamping-Ø at the same operating pressure mm	0,005	0,005	0,005	0,005	0,005	0,005	0,005	0,01	0,01
Max. roller peripheral speed m/min	800	800	800	725	725	725	715	700	700
Max. roller peripheral speed at half the max. clamping force per roller m/min	900	900	950	875	875	875	860	850	850
Displacement of the geometrical workpiece center in the event of a 20-70% change in the operating pressure /at constant force) mm	0,02	0,02	0,02	0,03	0,03	0,03	0,03	0,03	0,03

* At constant pressure and clamping force

Self-centering steady rests SLZN



Self-centering steady rests

Accessories SLZN

C 15 Cylindrical rollers



Item no.	For	A mm	B mm	Ø F mm	Ø O mm	Ø E mm	R mm
735120	SLZ 047	20	11,5	6	19	6	500
1835444▲	SLZN 067	28	17,5	8	24	8	500
1835388	SLZN/SLZNB 08105	31	20,5	15	35	15	500
649513	SLZN/SLZNB 1152, SLZN/SLZNB 1517, SLZN/SLZNB 40200	48	30	20	47	21	1000
649514	SLZN/SLZNB 325	60	40	20	52	21	3000
381420	SLZN/SLZNB 50315, SLZN/SLZNB 85350	75	45	20,1	60	21	3000

Rollers SLZ 047 and SLZNB 08105 without axle

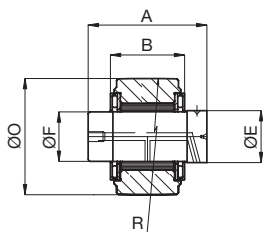

C 15 Convex rollers

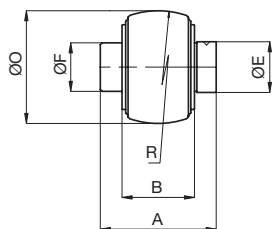

Item no.	For	A mm	B mm	Ø F mm	Ø O mm	Ø E mm	R mm
1835572▲	SLZN 067	28	17,5	8	24	8	100
1835513	SLZN/SLZNB 08105	31	20,5	15	35	15	100
649515	SLZN/SLZNB 1152, SLZN/SLZNB 1517, SLZN/SLZNB 40200	48	30	20	47	21	100
649516	SLZN/SLZNB 325	60	40	20	52	21	100
381426	SLZN/SLZNB 50315, SLZN/SLZNB 85350	75	45	20,1	60	21	500

C 15 Central scraper RZ



Item no.	For	Clamping ranges D1C mm	Clamping ranges D2C mm
836591	SLZ 047	15	62
1835423	SLZN 067	11	70
1835391	SLZN/SLZNB 08105	16	101
1831222	SLZN/SLZNB 1152	22	140
1831134	SLZN/SLZNB 1517, SLZN/SLZNB 40200	25/40	158/195
735005	SLZN/SLZNB 325	40	240
836584	SLZN/SLZNB 50315, SLZN/SLZNB 85350	50/85	305/345

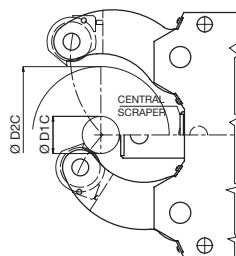

Accessories SLZN



Self-centering steady rests

Accessories SLZN

C 15
Central scraper RB

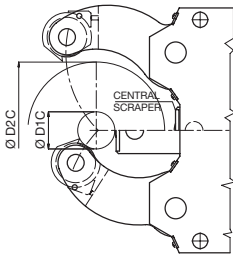

Item no.	For	Clamping ranges D1C mm	Clamping ranges D2C mm
1835573	SLZN/SLZNB 067	11	70
1835606	SLZN/SLZNB 08105	16	101
1831220	SLZN/SLZNB 1152	22	140
1831282	SLZN/SLZNB 1517, SLZN/SLZNB 40200	25/40	158/195
1831403	SLZN/SLZNB 325	40	240
836820	SLZN 50315, SLZN 85360	50/85	305/345

C 15
Chip protector outer Set = 2 Pieces



Item no.	For	Clamping ranges D1C mm	Clamping ranges D2C mm
836609	SLZ 047	15	62
1835435 ▲	SLZN 067	11	70
836610	SLZN/SLZNB 08105	16	101
836611	SLZN/SLZNB 1152, SLZN/SLZNB 1517, SLZN/SLZNB 40200	22/25/40	140/158/195
836612	SLZN/SLZNB 325	40	240
836613	SLZN/SLZNB 50315, SLZN/SLZNB 85350	50/85	305/345

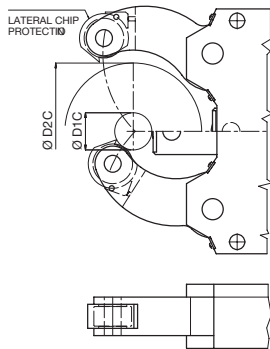



Self-centering steady rests

SLZNB - with side mounted cylinder

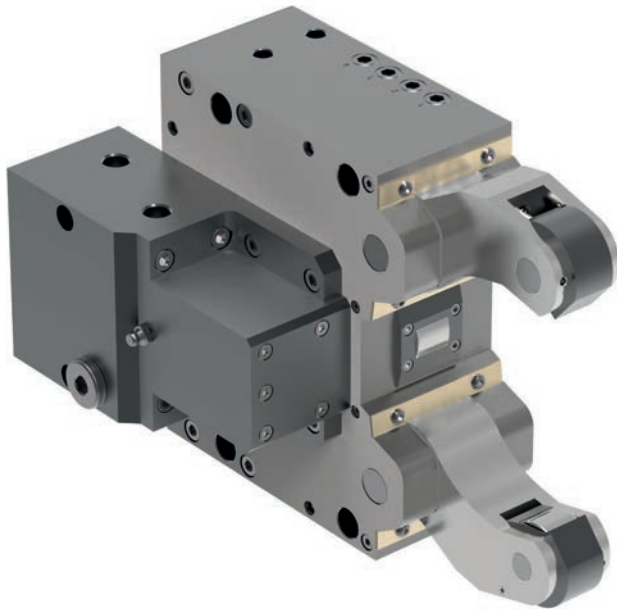

APPLICATION

Support of slender shafts for rational turning and end machining.

TYPE

Standard version with side mounted cylinder.

CUSTOMER BENEFITS

- ⊕ Flexible use when less back-space available
- ⊕ Large clamping range without change elements
- ⊕ Operational safety thanks to safety valve, even if pressure drops
- ⊕ High centering precision and repeatability thanks to proven cam lever system
- ⊕ Resilient chip protection for optimal workpiece wiping (for version „with chip protection“)
- ⊕ Purge air connection to prevent penetration of dirt inside the steady rest

TECHNICAL FEATURES

- Central lubrication or manual lubrication possible, depending on the operating conditions
- Standard version available with cylindrical or convex rollers
- Available with and without chip protection
- Prepared for end position check (limit switch not included in the scope of delivery)

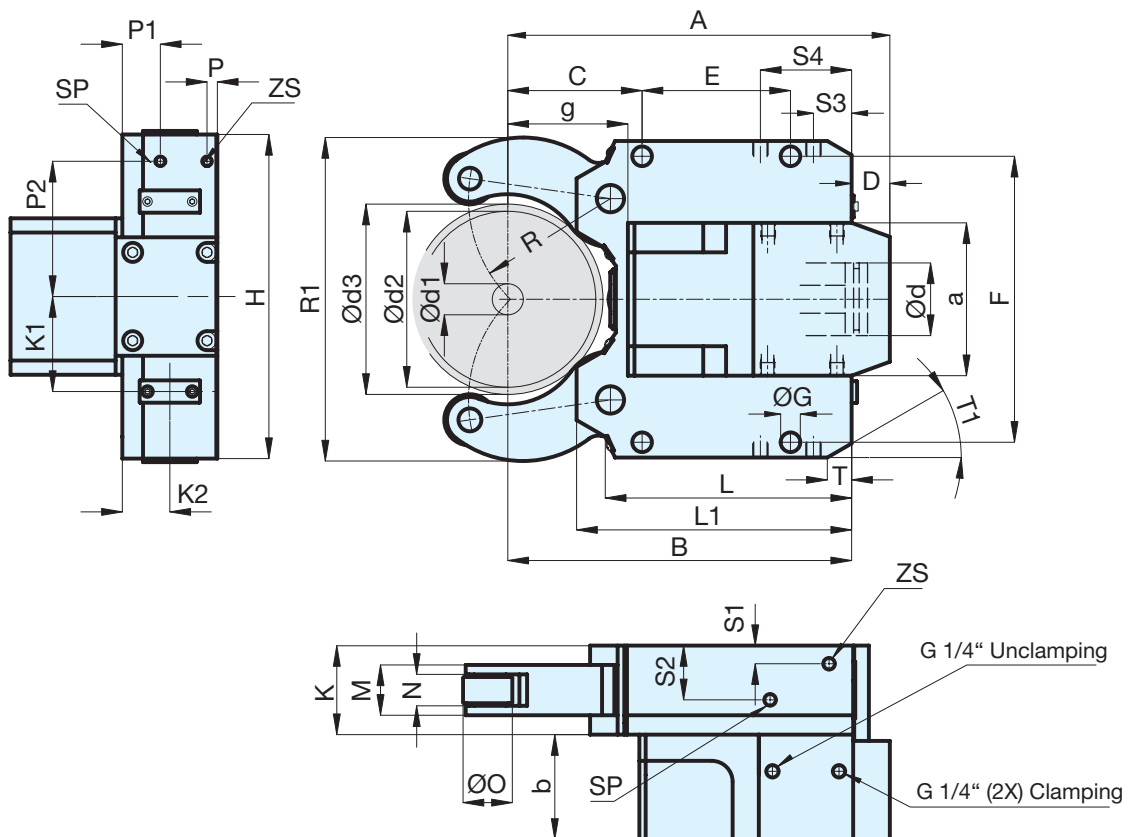

Self-centering steady rests SLZNB



Self-centering steady rests

SLZNB - with side mounted cylinder

C 15

Self-centering steady rests **SLZNB** - oil or air operated, with side mounted cylinder

Spannbereiche Typ	SLZNB 08105	SLZNB 1152	SLZNB 1517	SLZNB 40200	SLZNB 325	SLZNB 50315	SLZNB 85350
Clamping range - with chip protection mm	16-101	22-140	25-158	40-195	40-240	50-305	85-345
Clamping range - without chip protection mm	8-105	11-152	15-170	40-200	30-250	50-315	85-350
Max. radial clamping range - d _s mm	105	161	170	200	250	320	350
With chip protectors RZ	1685539 ▲	1685543 ▲	1685547 ▲	1685551 ▲	1685555 ▲	1685559 ▲	1685563 ▲
With chip protectors RB	1685540 ▲	1685544 ▲	1685548 ▲	1685552 ▲	1685556 ▲	1685560 ▲	1685564 ▲
Without chip protectors RZ	1685541 ▲	1685545 ▲	1685549 ▲	1685553 ▲	1685557 ▲	1685561 ▲	1685565 ▲
Without chip protectors RB	1685542 ▲	1685546 ▲	1685550 ▲	1685554 ▲	1685558 ▲	1685562 ▲	1685566 ▲
d1 mm	8	11	15	40	30	50	85
d2 mm	105	152	170	200	250	315	350
d3 mm	105	161	170	200	250	320	350
A mm	228	341	349	368	483,5	574	594
B mm	197	306	314	333	448	510	530
C mm	70	115	123	138	146	178	198
D mm	31	35	35	35	35,5	64	64
E mm	85	135	135	135	240	270	270
F mm	170	262	262	262	365	400	400
G mm	14	18	18	18	23	23	23
H mm	190	290	290	290	400	440	440
K mm	75	85	85	85	110	145	145
L mm	146	223	223	223	328,5	353,5	353,5
L1 mm	164	251	251	251	361	394,5	394,5
Clamping arm width M mm	35	48	48	48	60	75	75
Roller width N mm	20,5/18	30/25	30/25	30/25	40/35	45/40	45/40
O mm	35	47	47	47	52	60	60
P mm	-	9,5	9,5	9,5	12,5	21,5	21,5
P1 mm	-	34	34	34	12,5	68,5	68,5
P2 mm	-	117,5	117,5	117,5	160	183	183
R mm	74,5	122	130	143,5	178,5	209	229
S1 mm	10	-	-	-	-	-	-
S2 mm	40	-	-	-	-	-	-
S3 mm	28	-	-	-	-	-	-
S4 mm	28	-	-	-	-	-	-
K ₁ mm	59,5	85	85	85	110	140	140
K2 mm	36,5	42,5	42,5	42,5	55	59,5	59,5
a mm	95	140	140	140	180	180	180
b mm	71	98	98	98	124	143	143
d mm	50	80	80	80	100	100	100
g mm	68	102	110	129	169	196	216
T mm	-	-	-	-	48	54,5/22	54,5/22
T1	-	-	-	-	30°	18°/40°	18°/40°
R1 mm	192	291	303	326	403	486	512
Weight kg	14,5	51	51	52	134	194	198
ZS	G 1/8"	G 1/8"	G 1/8"	G 1/8"	G 1/8"	G 1/8"	G 1/8"
SP	G 1/8"	G 1/8"	G 1/8"	G 1/8"	G 1/8"	G 1/8"	G 1/8"
Cylinder-Ø	C50	C80	C80	C80	C100	C100	C100
Cylinder surface area cm ²	19,6	50	50	50	78,5	78,5	78,5
Max. operating pressure bar	53	62	68	40	57	80	61
Operating pressure bar	8-30	8-40	8-44	8-25	8-42	8-58	8-40
Clamping force per roller at max. operating pressure N	1960	6500	7000	4160	11000	15000	10460
Max. permissible clamping force per roller N	3500	10000	10000	6670	15000	20000	16000
Clamping force per roller at 20 bar N	1300	3300	3300	3300	5200	5200	5200
Centering accuracy over the entire clamping range mm	0,02*	0,04*	0,04*	0,04*	0,05*	0,06*	0,06*
Repeat accuracy for the same clamping-Ø at the same operating pressure mm	0,005	0,005	0,005	0,005	0,01	0,01	0,01
Max. roller peripheral speed m/min	800	725	725	725	715	700	700
Max. roller peripheral speed at half the max. clamping force per roller m/min	950	875	875	875	860	850	850
Displacement of the geometrical workpiece center in the event of a 20-70% change in the operating pressure /at constant force) mm	0,02	0,03	0,03	0,03	0,03	0,03	0,03

* At constant pressure and clamping force



Self-centering steady rests

Accessories SLZNB

C 15 Cylindrical rollers



Item no.	For	A mm	B mm	Ø F mm	Ø O mm	Ø E mm	R mm
1835388	SLZN/SLZNB 08105	31	20,5	15	35	15	500
649513	SLZN/SLZNB 1152, SLZN/SLZNB 1517, SLZN/SLZNB 40200	48	30	20	47	21	1000
649514	SLZN/SLZNB 325	60	40	20	52	21	3000
381420	SLZN/SLZNB 50315, SLZN/SLZNB 85350	75	45	20,1	60	21	3000

Rollers SLZNB 08105 without axle

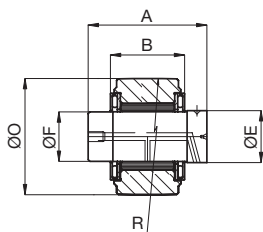

C 15 Convex rollers

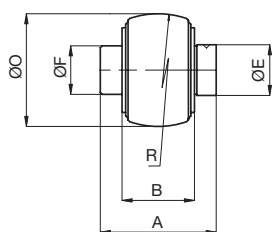

Item no.	For	A mm	B mm	Ø F mm	Ø O mm	Ø E mm	R mm
1835513	SLZN/SLZNB 08105	31	20,5	15	35	15	100
649515	SLZN/SLZNB 1152, SLZN/SLZNB 1517, SLZN/SLZNB 40200	48	30	20	47	21	100
649516	SLZN/SLZNB 325	60	40	20	52	21	100
381426	SLZN/SLZNB 50315, SLZN/SLZNB 85350	75	45	20,1	60	21	500

C 15 Central scraper RZ

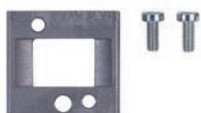

Item no.	For	Clamping ranges D1C mm	Clamping ranges D2C mm
1835391	SLZN/SLZNB 08105	16	101
1831222	SLZN/SLZNB 1152	22	140
1831134	SLZN/SLZNB 1517, SLZN/SLZNB 40200	25/40	158/195
735005	SLZN/SLZNB 325	40	240
836584	SLZN/SLZNB 50315, SLZN/SLZNB 85350	50/85	305/345

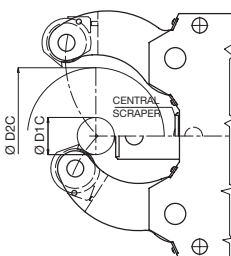

Accessories SLZNB



Self-centering steady rests

Accessories SLZNB

C 15
Central scraper RB

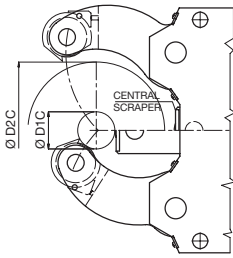

Item no.	For	Clamping ranges D1C mm	Clamping ranges D2C mm
1835606	SLZN/SLZNB 08105	16	101
1831220	SLZN/SLZNB 1152	22	140
1831282	SLZN/SLZNB 1517, SLZN/SLZNB 40200	25/40	158/195
1831403	SLZN/SLZNB 325	40	240
836820	SLZN 50315, SLZN 85360	50/85	305/345

C 15
Chip protector outer Set = 2 Pieces



Item no.	For	Clamping ranges D1C mm	Clamping ranges D2C mm
836610	SLZN/SLZNB 08105	16	101
836611	SLZN/SLZNB 1152, SLZN/SLZNB 1517, SLZN/SLZNB 40200	22/25/40	140/158/195
836612	SLZN/SLZNB 325	40	240
836613	SLZN/SLZNB 50315, SLZN/SLZNB 85350	50/85	305/345

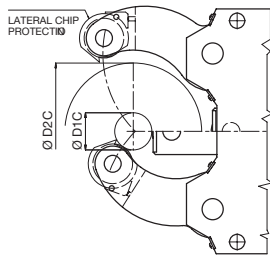



Self-centering steady rests

SLZ - heavy design

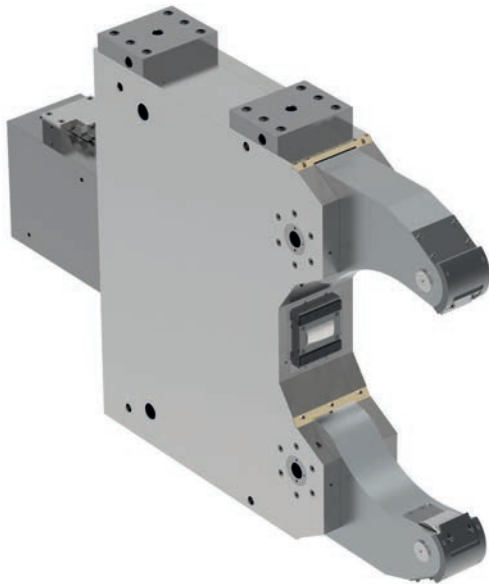

APPLICATION

Support of shafts for rational turning and end machining preferential for heavy solid materials.

TYPE

Heavy design for high loads.

CUSTOMER BENEFITS

- ③ Large clamping range without change elements
- ③ Operational safety thanks to safety valve, even if pressure drops
- ③ Sturdy design for variable use - Increased stability thanks to steady rest fastened with clamping arm axis
- ③ High centering precision and repeatability thanks to proven cam lever system
- ③ Resilient chip protection for optimal workpiece wiping (for version „with chip protection“)
- ③ Purge air connection to prevent penetration of dirt inside the steady rest

TECHNICAL FEATURES

- Central lubrication or manual lubrication possible, depending on the operating conditions
- Standard version available with cylindrical or convex rollers
- Available with and without chip protection
- Prepared for end position check (limit switch not included in the scope of delivery)
- Recommendation: Higher precision in case of vertical installation of the steady rest

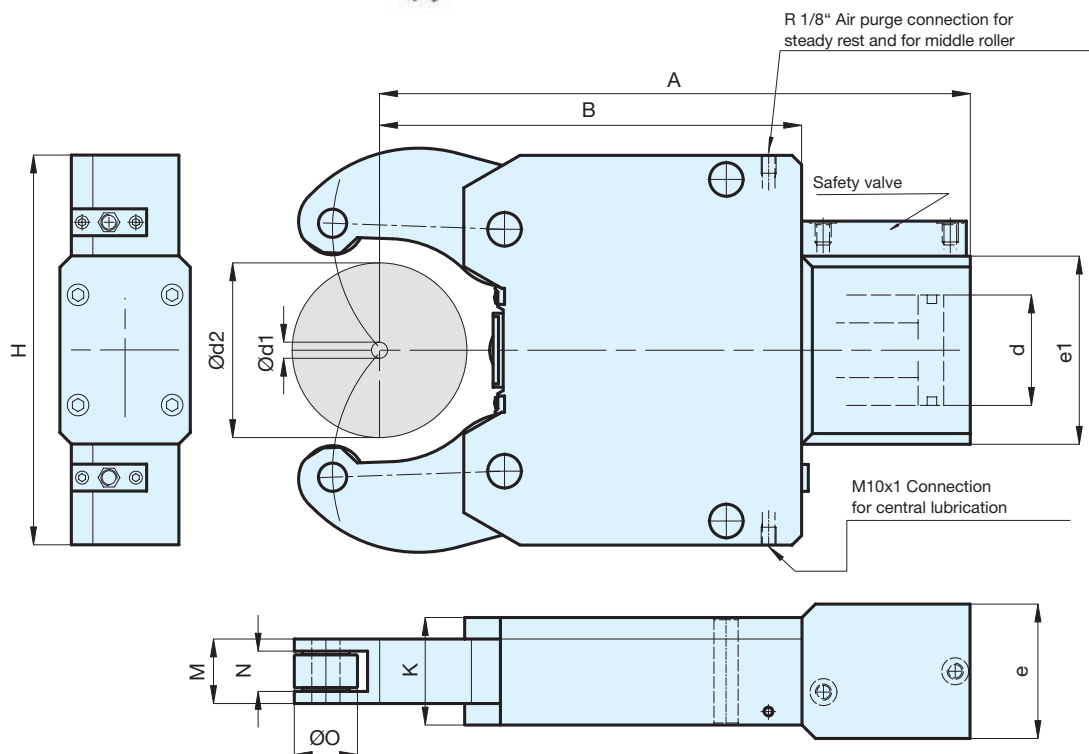

Self-centering steady rests SLZ - heavy design



Self-centering steady rests

SLZ - heavy design

C 15

Self-centering steady rests **SLZ heavy design** - oil or air operated, heavy design for high loads

Spannbereiche Typ	SLZ 437	SLZ 5040	SLZ 1546	SLZ 1060	SLZ 3580
Clamping range - with chip protection mm	75-350	75-380	150-430	100-590	350-770
Clamping range - without chip protection mm	40-375	50-400	150-460	100-600	350-800
With chip protectors RZ	685899 ▲	1685722 ▲	685897 ▲	685896 ▲	685895 ▲
With chip protectors RB	685894 ▲	685893 ▲	685892 ▲	685891 ▲	685890 ▲
Without chip protectors RZ	685889 ▲	685888 ▲	685887 ▲	685886 ▲	685885 ▲
Without chip protectors RB	685884 ▲	685883 ▲	685882 ▲	685881 ▲	685880 ▲
d1 mm	40	50	150	100	350
d2 mm	370	400	460	600	800
A mm	1086	1100	1110	1465	1810
B mm	762	800	800	1105	1340
H mm	730	730	730	1020	1270
K mm	170	170	170	270	440
Clamping arm width M mm	90	90	90	170	240
Roller width N mm	60/50	60/50	60/50	104/95	150/138
O mm	80	80	80	160	220
d mm	120	120	120	150	180
e mm	150	150	150	260	370
e1 mm	240	240	240	280	320
Weight kg	490	500	570	2000	4000
Cylinder-Ø	C120	C120	C120	C150	C180
Cylinder surface area cm ²	113	113	113	176	254
Max. operating pressure bar	100	100	85	90	98
Operating pressure bar	10-40	10-40	10-40	10-40	10-40
Clamping force per roller at max. operating pressure N	15000	15000	15000	23000	32000
Max. permissible clamping force per roller N	35000	35000	40000	50000	80000
Centering accuracy over the entire clamping range mm	0,04*	0,04*	0,04*	0,04*	0,06*
Repeat accuracy for the same clamping-Ø at the same operating pressure mm	0,01	0,01	0,01	0,01	0,01
Max. roller peripheral speed m/min	725	725	725	725	715
Max. roller peripheral speed at half the max. clamping force per roller m/min	875	875	875	875	860
Displacement of the geometrical workpiece center in the event of a 20-70% change in the operating pressure /at constant force) mm	0,06	0,06	0,06	0,06	0,06

*1 At constant pressure and clamping force



Self-centering steady rests

SLZC - extremely compact design

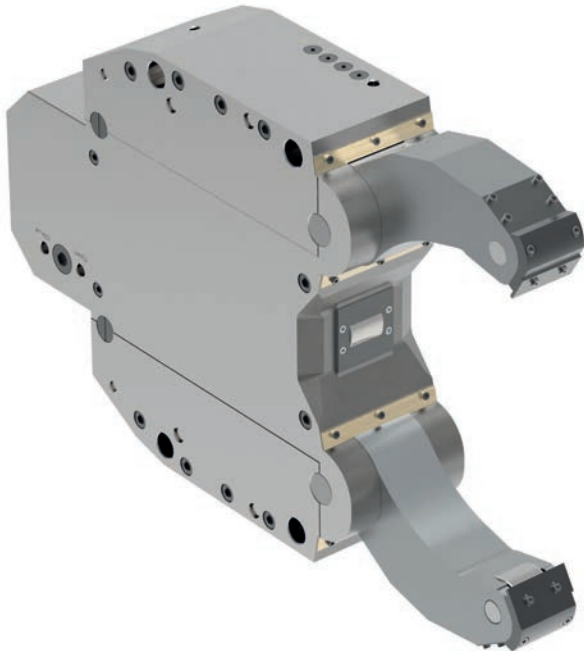

APPLICATION

Support of shafts for rational turning and end machining optimal for pipe materials.

TYPE

Compact series with extra large clamping ranges.

CUSTOMER BENEFITS

- ⊕ Extra large clamping range without change elements
- ⊕ Integrated channels for rinsing the workpiece in the contact area with coolant connection on the rear side
- ⊕ Operational safety thanks to safety valve, even if pressure drops
- ⊕ Extremely compact and sturdy design for variable use
- ⊕ High centering precision and repeatability thanks to proven cam lever system
- ⊕ Resilient chip protection for optimal workpiece wiping (for version „with chip protection“)
- ⊕ Purge air connection to prevent penetration of dirt inside the steady rest

TECHNICAL FEATURES

- Central lubrication or manual lubrication possible, depending on the operating conditions
- Standard version available with cylindrical or convex rollers
- Available with and without chip protection
- Prepared for end position check (limit switch not included in the scope of delivery)

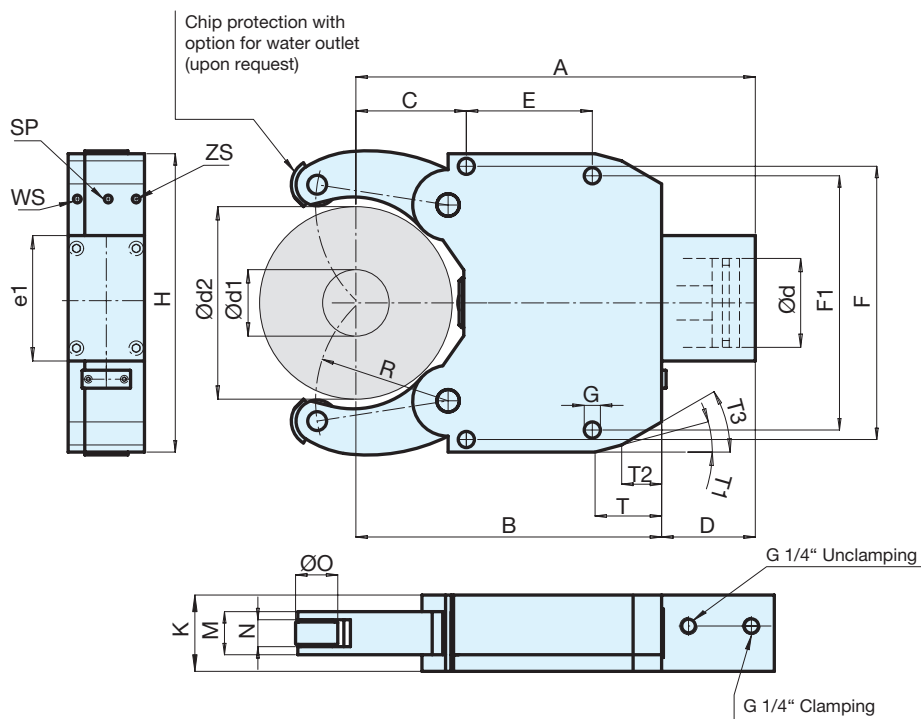

Self-centering steady rests SLZC



Self-centering steady rests

SLZC - extremely compact design

C 15

Self-centering steady rests **SLZC - oil or air operated**, extremely compact design, developed for minimum mounting dimensions

Spannbereiche Typ	SLZC 60280	SLZC 80390	SLZC 100410	SLZC 135460	SLZC 215510
Clamping range - without chip protection mm	60-280	80-390	100-410	135-460	215-520
With chip protectors RZ	1685616 ▲	1685620 ▲	1685624 ▲	1685628 ▲	1685632 ▲
With chip protectors RB	1685617 ▲	1685621 ▲	1685625 ▲	1685629 ▲	1685633 ▲
Without chip protectors RZ	1685618 ▲	1685622 ▲	1685626 ▲	1685630 ▲	1685634 ▲
Without chip protectors RB	1685619 ▲	1685623 ▲	1685627 ▲	1685631 ▲	1685635 ▲
d1 mm	60	80	100	135	215
d2 mm	280	390	410	460	520
A mm	580	755	763	816	817
B mm	450	607	617	670	685
C mm	168	230	240	215	245
D mm	130	148	146	146	132
E mm	180	240	240	330	300
F mm	360	445	445	640	640
F1 mm	360	445	445	610	610
G mm	23	23	23	27	27
H mm	400	485	485	680	680
K mm	125	150	150	150	150
Clamping arm width M mm	60	75	75	75	75
Roller width N mm	40/35	45/40	45/40	29	29
O mm	52	60	60	80	80
R mm	200	265	275	290	310
d mm	90	100	100	120	120
e1 mm	184	194	194	215	215
T mm	100	130	130	150	150
T1	15°	15°	15°	15°	20°
T2 mm	61	50	50	77	85
T3 mm	30°	30°	30°	30°	30°
Weight kg	85	170	170	390	380
ZS	G 1/8"	G 1/8"	G 1/8"	G 1/8"	G 1/8"
SP	G 1/8"	G 1/8"	G 1/8"	G 1/8"	G 1/8"
WS	G 1/4"	G 1/4"	G 1/4"	G 1/4"	G 1/4"
Operating pressure bar	8-70	8-80	8-80	8-80	8-80
Max. permissible clamping force per roller N	14500	20000	20000	25000	25000
Centering accuracy over the entire clamping range mm	0,05*	0,06*	0,06*	0,06*	0,06*
Repeat accuracy mm	0,007*	0,01*	0,01*	0,01*	0,01*
Max. roller peripheral speed m/min	715	700	700	700	700

* At constant pressure and clamping force
Water connection (WS) on request



Self-centering steady rests

SLZK - slim clamping arms

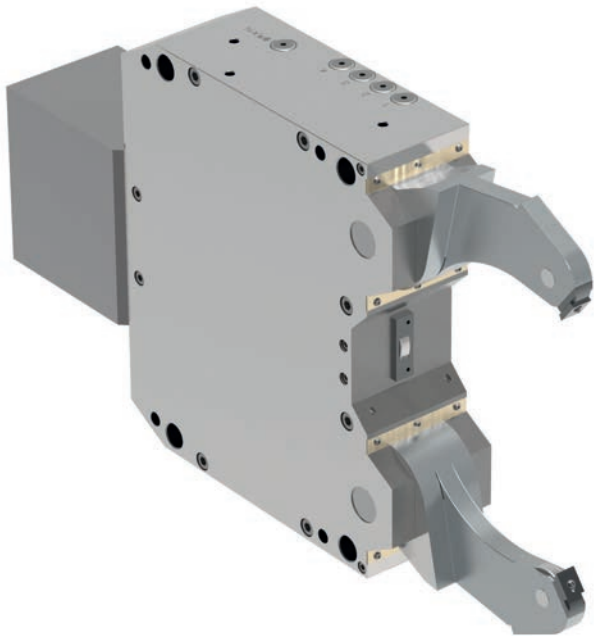

APPLICATION

Support of slender shafts with narrow intermediate distances for rational turning and end machining optimal for crankshafts and cam shafts.

TYPE

Version with extra slim clamping arms.

CUSTOMER BENEFITS

- ⊕ Can be flexibly used thanks to support option in narrow in-between spaces
- ⊕ Large clamping range without change elements
- ⊕ Operational safety thanks to safety valve, even if pressure drops
- ⊕ Compact and sturdy design for variable use
- ⊕ High centering precision and repeatability thanks to proven cam lever system
- ⊕ Resilient chip protection for optimal workpiece wiping (for version „with chip protection“)
- ⊕ Purge air connection to prevent penetration of dirt inside the steady rest

TECHNICAL FEATURES

- Central lubrication or manual lubrication possible, depending on the operating conditions
- Standard version available with cylindrical rollers
- Available with and without chip protection
- Prepared for end position check (limit switch not included in the scope of delivery)

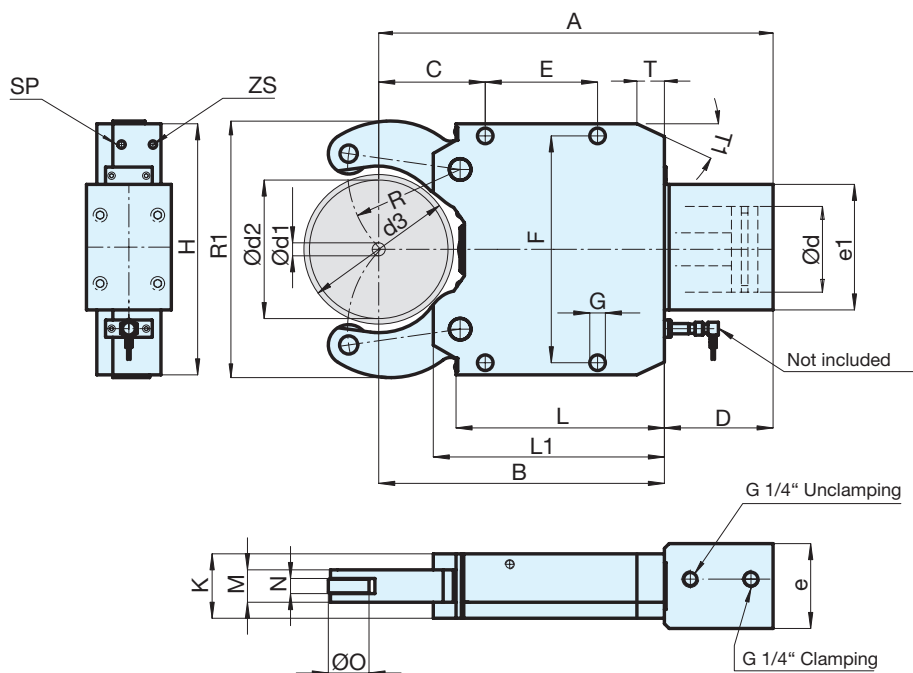

Self-centering steady rests SLZK



Self-centering steady rests

SLZK - slim clamping arms

C 15

Self-centering steady rests **SLZK** - oil or air operated, with slender clamping arms, for machining crankshafts

Spannbereiche Typ	SLZK 08101-15	SLZK 08101-19	SLZK 08101-22	SLZK 40200-18	SLZK 40200-22	SLZK 325-19	SLZK 325-22	SLZK 325-29
Clamping range - with chip protection mm	16-101	16-101	16-101	30-185	30-185	35-248	35-248	35-248
Clamping range - without chip protection mm	8-105	8-105	8-105	30-185	30-185	35-250	35-250	35-250
With chip protectors RZ	1685636 ▲	1685638 ▲	1685640 ▲	1685642 ▲	1685644 ▲	1685646 ▲	1685648 ▲	1685650 ▲
Without chip protectors RZ	1685637 ▲	1685639 ▲	1685641 ▲	1685643 ▲	1685645 ▲	1685647 ▲	1685649 ▲	1685651 ▲
d1 mm	8	8	8	30	30	35	35	35
d2 mm	105	105	105	185	185	250	250	250
d3 mm	106	106	106	190	190	254	254	254
Max. Ø opening range d4sw mm	113	113	113	200	200	263	263	263
A mm	279,5	279,5	279,5	458,5	458,5	617,5	617,5	617,5
B mm	197	197	197	333	333	451	451	451
C mm	70	70	70	138	138	146	146	146
D mm	82,5	82,5	82,5	125,5	125,5	166,5	166,5	166,5
E mm	85	85	85	135	135	240	240	240
F mm	170	170	170	262	262	365	365	365
G mm	14	14	14	18	18	23	23	23
H mm	190	190	190	290	290	400	400	400
K mm	50	50	50	85	85	110	110	110
L mm	143	143	143	223	223	331,5	331,5	331,5
L1 mm	164	164	164	251	251	364	364	364
Clamping arm width M mm	15	18	22	18	22	19	22	29
Roller width N mm	8	10	13	11	13	11	13	16
O mm	35	35	35	47	47	52	52	52
R mm	74,5	74,5	74,5	143,5	143,5	183	183	183
d mm	50	50	50	60	60	60	60	60
e mm	68	68	68	98	98	124	124	124
e1 mm	92	92	92	145	145	156	156	156
T mm	-	-	-	-	-	45	45	45
T1	-	-	-	-	-	30°	30°	30°
R1 mm	190	190	190	320	320	394	394	394
Weight kg	11,5	11,5	11,5	40	40	80	80	80
ZS	G 1/8"	G 1/8"	G 1/8"	G 1/8"	G 1/8"	G 1/8"	G 1/8"	G 1/8"
SP	G 1/8"	G 1/8"	G 1/8"	G 1/8"	G 1/8"	G 1/8"	G 1/8"	G 1/8"
Operating pressure bar	8-32	8-40	8-50	8-60	8-75	8-70	8-80	8-80
Max. permissible clamping force per roller N	2100	2700	3350	5600	7000	6600	7500	7500
Centering accuracy over the entire clamping range mm	0,03*	0,03*	0,03*	0,05*	0,05*	0,06*	0,06*	0,06*
Repeat accuracy mm	0,007*	0,007*	0,007*	0,007*	0,007*	0,01*	0,01*	0,01*
Max. roller peripheral speed m/min	750	750	750	715	715	700	700	700

* At constant pressure and clamping force



Grinding steady rest SLVZ

Grinding steady rest SLVZ

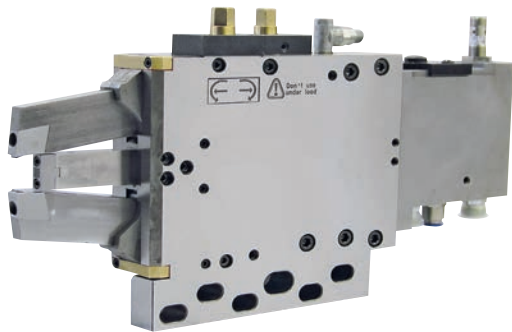

Grinding steady rest SLVZ - with retractable arms

APPLICATION

Grinding machining on CNC grinding machines. As support for long shafts, for internal machining or grinding directly on the seat of the steady rest.

TYPE

Equipped with fine adjustment in X and Y axes. Standard version with carbide jaws. With PKD (diamond) jaws on request.

CUSTOMER BENEFITS

- ⊕ Free work area and automatic workpiece loading thanks to retractable arms in the steady rest body
- ⊕ Small dimensions and high positioning accuracy and repeatability by means of fine adjustment in the X and Y axes

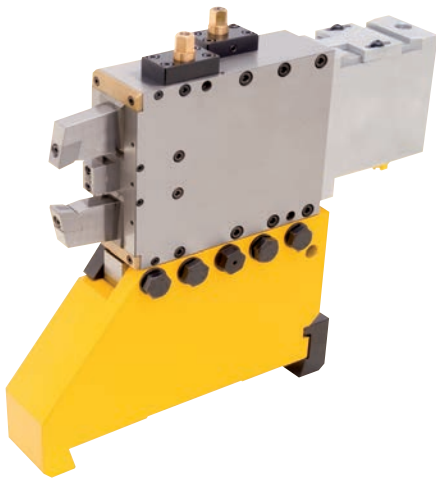

Grinding steady rest SLVZ with extended arms



Grinding steady rest SLVZ with retracted arms

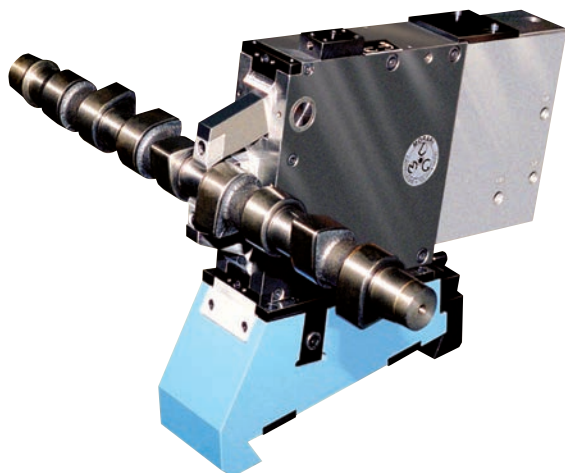

Steady rest SLVZ in use



Grinding steady rest SLVZ

Grinding steady rest SLVZ

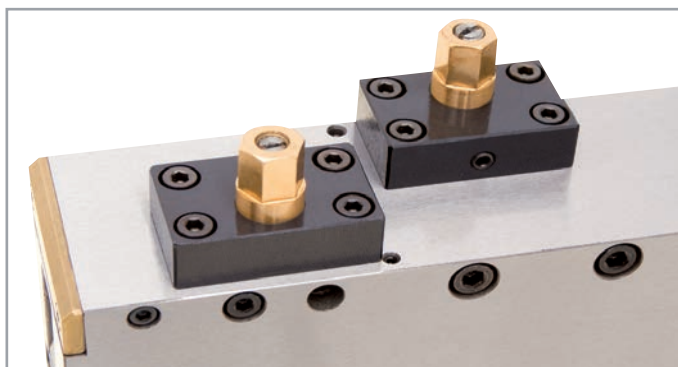

μ -exact fine adjustment for exactly setting up the steady rests. This system allows an easy and quick set-up, if several steady rests are used for the same workpiece. The control system for opening and closing is included in the standard version for all steady rests. The hydraulic or pneumatic connections can be attached according to customer requirements. It is recommended that no pressure changes occur during operation.

Main features:

- ⌚ Carbide jaws (CBN) or PKD on request (polycrystalline diamond)
- ⌚ Hydraulic or pneumatic actuation
- ⌚ High centering precision
- ⌚ Allows grinding machining on the seat of the steady rest
- ⌚ High repeatability
- ⌚ Stroke control for clamping and open positions
- ⌚ Compact, rigid structure
- ⌚ Customized versions on request



Steady rest solutions

Steady rest solutions - on request

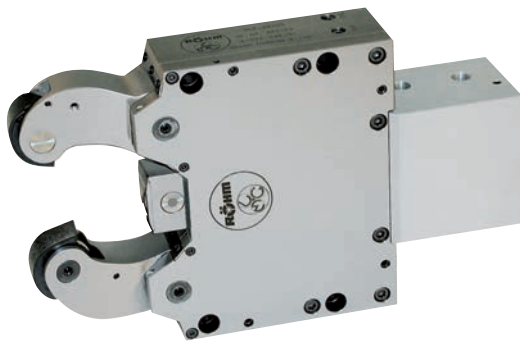

SLZW - One extra opening clamping arm

APPLICATION

For applications where simple loading is decisive.

TYPE

Hydraulically or pneumatically actuated one extra opening clamping arm.

CUSTOMER BENEFITS

- Simple loading of the workpiece

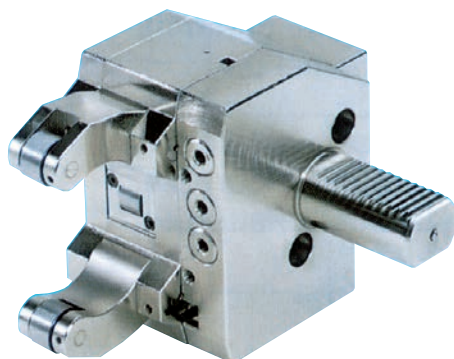
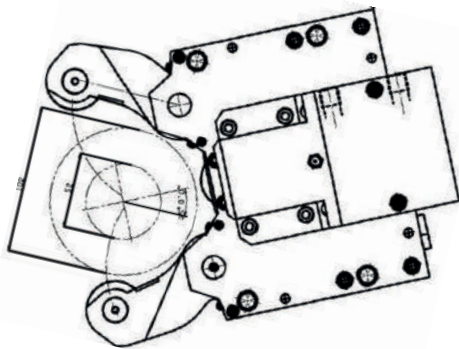

SLZR

APPLICATION

For turret discs of CNC lathes with 4 axes.

TYPE

Hydraulically or pneumatically actuated. Take-up shaft in acc. with DIN 69880.

CUSTOMER BENEFITS

- Rational machining of shaft-type components in 4-axis CNC lathes



Mounting examples

Mounting examples

Reaming: crank shafts

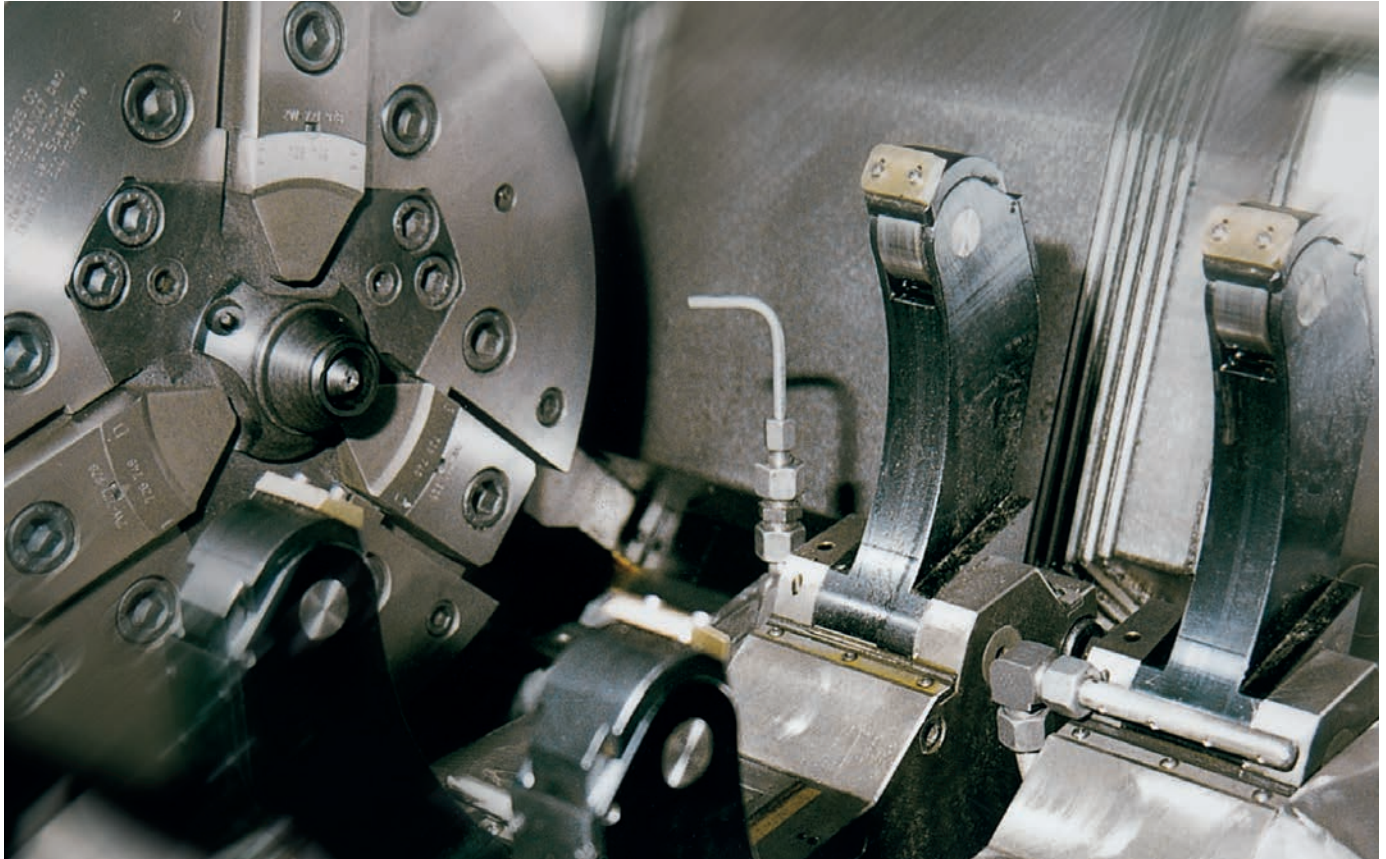

Turning: sleeves

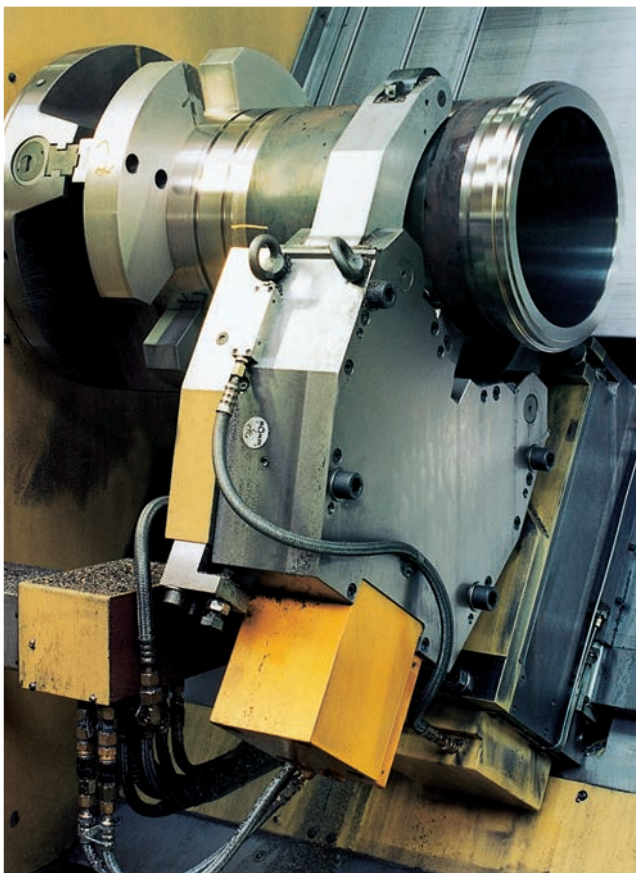

Turning: load hooks

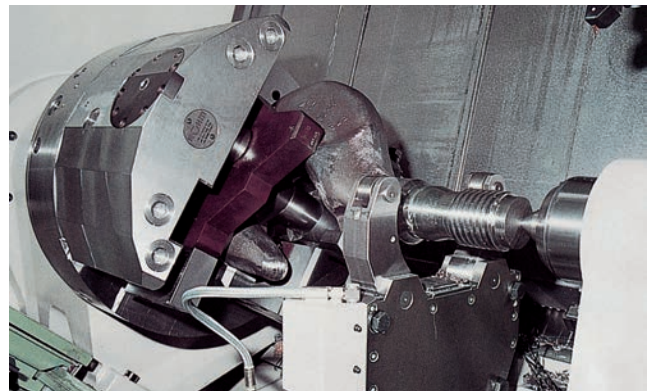

Turning: adaptor cages

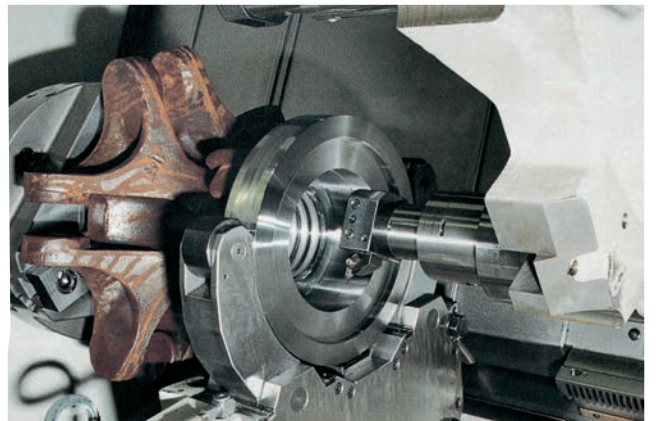

Mounting examples